



POST TENSIONING FOR SLAB

Document DTS-PT-GEN-001 (DTS-004)
Rev.2 - date: 2008
Prepared by: Technical Office
Technical Department TENSACCIAI srl

INDEX

1. Introduction	3
2. Post-tensioned slabs - Advantages	4
3. Post-tensioned slabs - Application	7
3.1 Suspended slabs	10
3.2 Slab on ground	11
4. Post-tensioning slab design	12
5. TENSACCIAI slab post-tensioning systems	19
6. Post tensioning slabs - Construction	27
6.1 Suspended slabs	27
6.1.1 Slabs with removable forms	27
6.1.2 Slabs on carton forms	28
6.1.3 Slabs on metal deck	28
6.1.4 Composite slabs on metal deck	28
6.1.5 Topping slabs on precast concrete	29
6.2 Slabs on ground	30
6.3 Work method statement	32
7. Post tensioning slabs - Durability	36
8. Future prospects	38

1. Introduction

Post-tensioned concrete slabs have become a major factor on the construction of floor systems for commercial and residential buildings of all types. In their two most popular forms (one way slabs, two way flat plates) they have been found to be economical for structural applications in parking structures, apartment buildings, office buildings, hospitals and industrial buildings of both the high rise and low rise type.



One of the main reasons that led to the development of this technology is that post-tensioning can solve simultaneously weight, deflection and cracking problems, which arose with conventionally reinforced slabs. Other major factor which contributed to the growth of post-tensioned slab construction included:

- Improvements and simplifications in post-tensioning hardware and field methods, making post-tensioned slab construction as easy for the contractor as conventionally reinforced slabs
- Improvements in forming systems, which enhanced the overall economics of cast-in-place slab construction
- Testing programs on post-tensioned slabs, which greatly expanded the understanding of their behaviour, and led to improved code criteria and more economical, safe designs

While more conventional reinforced is used, both for minimum crack distribution steel and for strength requirements, the combined use of prestressed and non-prestressed reinforcement results in considerable savings compared to the previous highly post-tensioned slabs.

2. Post-tensioned slabs - Advantages

The primary reason for the initial economy of post-tensioned industrial floors is the reduced thickness of the concrete slab, permitted because of the compressive stress induced in the concrete by the post-tensioning tendons. Additional reductions in costs are provided by elimination of most slab joints, reduced construction time and, in some cases, the elimination of pile supports or drilled shafts. For floors of prefabricated metal buildings, the post-tensioning also serves as a horizontal tie for the horizontal reaction from the building columns. This eliminates the need for conventional reinforcing bars in the slab to dissipate the column reaction into the slab, and at the same time eliminates the possibility of slab cracking associated with such details. In addition to economic advantages, present day design criteria for post-tensioned slabs result in improvements in overall behaviour (lower compression stresses and more bonded reinforcement reduce and distribute cracking caused by axial shortening restraints. Such slabs generally have much less cracking than conventionally reinforced slabs. Design criteria and technology for post-tensioned slabs have been developed to a level comparable to that available for conventionally reinforced slabs. In detail, the advantages of the use of post-tensioned slab can be summarised as follows:



- Control of Cracks - Post-tensioned slabs control cracks much better than other reinforced slabs, due to the squeezing pressure (tension) of the cables compressing the cracks.
- Time Savings - Post-tensioned can be installed much faster than other reinforced foundation systems. A typical residential foundation takes 3-4 hours to install. Time is also saved by, using fewer joints, narrower footings, less digging, and easier to clean up in the event of inclement weather.

- **Reinforcing Savings** - As steel and concrete increase in pricing, the savings with a post-tensioned slab will increase, because the quantity of steel and concrete required for a post-tensioned slab is less than for a conventionally reinforced foundation. Clean out of the footings after a rain is much faster and neater than re-bar type foundations.
- **Fewer Joints** - Large concrete areas, such as tennis courts, parking lots, warehouses, metal buildings can have joint spacing increased to minimize cost of joints and long-term maintenance of the joints.
- **Deflection Control** - Post-tensioning increases the slab stiffness and by its increased flexural and tensile capacities. For example in presence of expansive soils, it's obviously that post-tensioned slab are more resistant. Infact, movement of soils can sometimes be significant enough to move the structure (slab on ground support foundation systems are still interactive with the soil).
- **Improved Modulus of Rupture** - It is a fact that concrete shrinks when it dries and cracks. By utilizing a two part tensioning process, shrinkage cracking can be reduced.
- **Improved Flatness and Slab Levelness** - With fewer joints and greater joint spacing, slab curling is greatly reduced.
- **Reduction in slab thickness** – Minimum floor thickness maximises the ceiling zone available for horizontal services, minimises the self weight and foundation loads, and keeps down the overall height of the building.

	First direct advantage	Related further advantages
DESIGN	Reduction in slab thickness	<ul style="list-style-type: none"> • Floor to floor distance reduction • Savings on total building height (1 floor gained each 20 foreseen) • Reduction of construction volumes and consequent energy needed for heating, cooling living spaces • Different opportunities for ceiling final finishing.
	Larger spans (and reduction of columns)	<ul style="list-style-type: none"> • Increase of free space available • More architectural opportunities
	Reduction in slab weight	<ul style="list-style-type: none"> • Savings on vertical structural bearing members and foundations.
	High limitation of crack widths	<ul style="list-style-type: none"> • Improvement of durability and concrete behavior.
	High deflection limitation	<ul style="list-style-type: none"> • Improvement of serviceability for all structural members
CONSTRUCTION	Reduction of steel reinforcement and arrangement simplification	<ul style="list-style-type: none"> • Easier materials placing and handling.
	High deflection limitations due to concrete shrinkage and creep	<ul style="list-style-type: none"> • Possible earlier formworks removal.
	High repeatability from floor to floor / quick rotation of formworks	<ul style="list-style-type: none"> • Reduction of erection times • Reduction of formworks sets • Improvement of constructability

3. Post-tensioned slabs - Application

PT reinforcement is used more in the residential market than in any other sector of construction. Anyway, application for the post-tensioning slabs system include:

- Low to high rise residential and commercial buildings
- Industrial floor slabs on the ground
- Transfer floor structures
- Car parks
- Water tank bases and walls
- Transverse stressing of bridge decks

There are two types of PT systems: bonded and unbonded. Unbonded systems use strands surrounded with special corrosion-inhibiting grease and encased in waterproof plastic sheaths. This assembly is positioned, and then the concrete is placed, similar to standard reinforced concrete. With a bonded system, before the concrete is cast, empty steel or plastic ducts are positioned in the formed area and attached to the anchorages at either



end. After the concrete is placed and gains strength, strands are threaded through the ducts, tensioned, and the ducts are filled with a special grout designed to prevent corrosion. Unbonded systems are nearly always used for building and slab construction, while bonded systems are mostly for bridge construction. The more recent development of post-tensioning specifically for in-situ floor slab construction has result in the two mentioned system. With the bonded system the prestressing tendons run through small continuous flattened ducts which are grouted after the tendons are stressed. The system has been used successfully in general floor slab construction and is often used for

specialist applications. The most efficient prestress design is when the prestressing tendon is positioned eccentrically in the concrete section on a curved profile or deflected from a straight line. The size of the duct used in a bonded system and the minimum cover that must be provided may control the maximum eccentricity that can be achieved. The ducts are formed by spirally-wound or seam folded galvanised metal strip. The limit on the curvature or profile that can be achieved with the prestressing tendons is dependent on the flexibility of the ducts. The ducts have to be grouted after stressing, which introduces a further trade into the construction process.

In an unbonded system the tendon is not grouted and remain free to move independently of the concrete. This has no effect on the serviceability design or performance of a structure under normal working conditions. It does, however, change both the design theory and structural performance at the ultimate limit state, which is preceded by larger deflections with fewer, but larger, associated cracks, than with an equivalent bonded system. Thus, with an unbonded system there are obvious visual indications that something is wrong well before failure occurs. In an



unbonded system, tendons can be located close to the surface of the concrete to maximise the eccentricity. Tendons are flexible and can be easily fixed to different profiles. They can be displaced locally around holes, and to accommodate changes in slab shape. The stressing operation is simple and with no grouting, is suited to rapid construction method.

Stage stressing is a technique of applying stress to the tendons in stages, as the concrete progressively gets stronger. This technique helps to avoid early cracking in slabs.

When planning a prestressed concrete structure, care must be taken to avoid the problems of restraints. This is where the free movement in the length of the slab under the prestress forces is restrained, for example by the unfavourable positioning of shear walls or lift cores. There are two components to the applied prestress: the direct axial compression in the concrete section transferred through the tendon anchorage, and the upward force from the tendon profile. If the slab is restrained when the slab is stressed, force may be lost into the restraining element instead of being fully transferred to the slab. This may result in a loss of axial compression but will not affect the upward force. A significant loss of axial compression force could cause the slab to crack.

3.1 Suspended slabs

Many types of suspended slab structures typically realise the benefits of post-tensioning, such as car parks, apartment buildings, commercial office space, retail centres, vertical load transfer structures, hospitals, storage facilities and public buildings (for example, stadiums, exhibition centres, schools and institutional facilities). In general, suspended floor systems fall into four main categories:

1. Cast-in-place suspended floors;
2. Slabs with removable forms;
3. Slabs on metal decking; and
4. Topping slabs on precast concrete.

Different formwork systems are compatible with post-tensioning, namely: conventional plywood systems, permanent metal deck systems, ribbed slabs, precast systems.

Buildings with post-tensioned slabs are a widely used application of prestressed concrete. This method achieves performance and construction improvements over other construction methods. However, in order to reap the benefits of this method, proficiency is required in both structural design and construction.

Post-tensioned slabs is a preferred method for industrial, commercial and residential floor slab construction. The extensive use of this method is due to its advantages and its nature of easy applicability to a wide variety of structure geometry and design solutions. Floor systems can be classified in several different ways. Flat slabs can be solid, voided or waffle. Waffle slabs, banded or beam and slab systems are structurally more efficient for increasing span lengths and/or live load.

3.2 Slab on ground

PT reinforcement is commonly used in regions with poor soils: expansive soils, seasonal water accumulations, collapsing soils, and areas subject to long-term drying. PT stiffens slabs so that they can serve as foundations and resist any soil movements. The post-tensioning of slabs on ground is providing many developers and builders with a cost effective pavement solution. Benefits realized with post-tensioned slabs on ground include:

- Large joint free slab area
- Less sub base preparation and/or excavation
- Faster construction time

Facilities that have adopted a post tensioned slab on ground system include distribution warehouses, freezer stores, container terminal facilities, rail freight facilities, aircraft hangers, water retaining structures, sporting venues and raft slabs.

For example, the foundation slabs for apartments and condominiums require more conventional reinforcement than residential homes. It has been found that the heavier the conventional design, the more economical the post-tensioning alternative becomes.

4. Post-tensioning slab design

PT slabs are designed to withstand the usual imposed floor loads such as vehicle wheels, racking posts, pallets and so on. Post-tensioning enhances the slab's moment resisting capacity and for heavily loaded slabs, this usually leads to selection of a reduced slab thickness compared to that required for conventionally reinforced slabs. All slab design are sensitive to differing sub grade strengths but the post-tensioning provides inherent advantages because it gives the slab the ability to bridge over local sub grade failures and even recover its original shape after repair of these failures (for example, by pressure grouting under the slab).

Post-tensioned floors may be totally of in-situ concrete or a hybrid of in-situ and precast concrete. Either may be prestressed or a combination of prestressed and reinforced.

For most multi-storey buildings there is a suitable concrete framing system. For example, for span greater than 6m, post-tensioned slabs become to be cost-effective, and can be used alone or combined with reinforced concrete to provide a complementary range of in-situ concrete floor options. The three main forms of construction are:

- Solid flat slab – 6m to 13m – An efficient post-tensioned design can be achieved with a solid flat slab, which is ideally suited to multi-storey construction where there is a regular column grid. These are sometimes referred to as flat plate slabs. The benefits of a solid flat slab are the flush soffit and minimum construction depth, which are suited to rapid constructions method. These provide the maximum flexibility for horizontal service distribution and keep slab weight low and building height down to a minimum. The dept of a flat slab is usually controlled by deflection requirements or by the punching shear capacity around the column. Post-tensioning improves control of deflections and enhances shear capacity. The latter can be increased further by introducing steel shear heads within the slab depth (a), column heads (b) or drop panels (c).

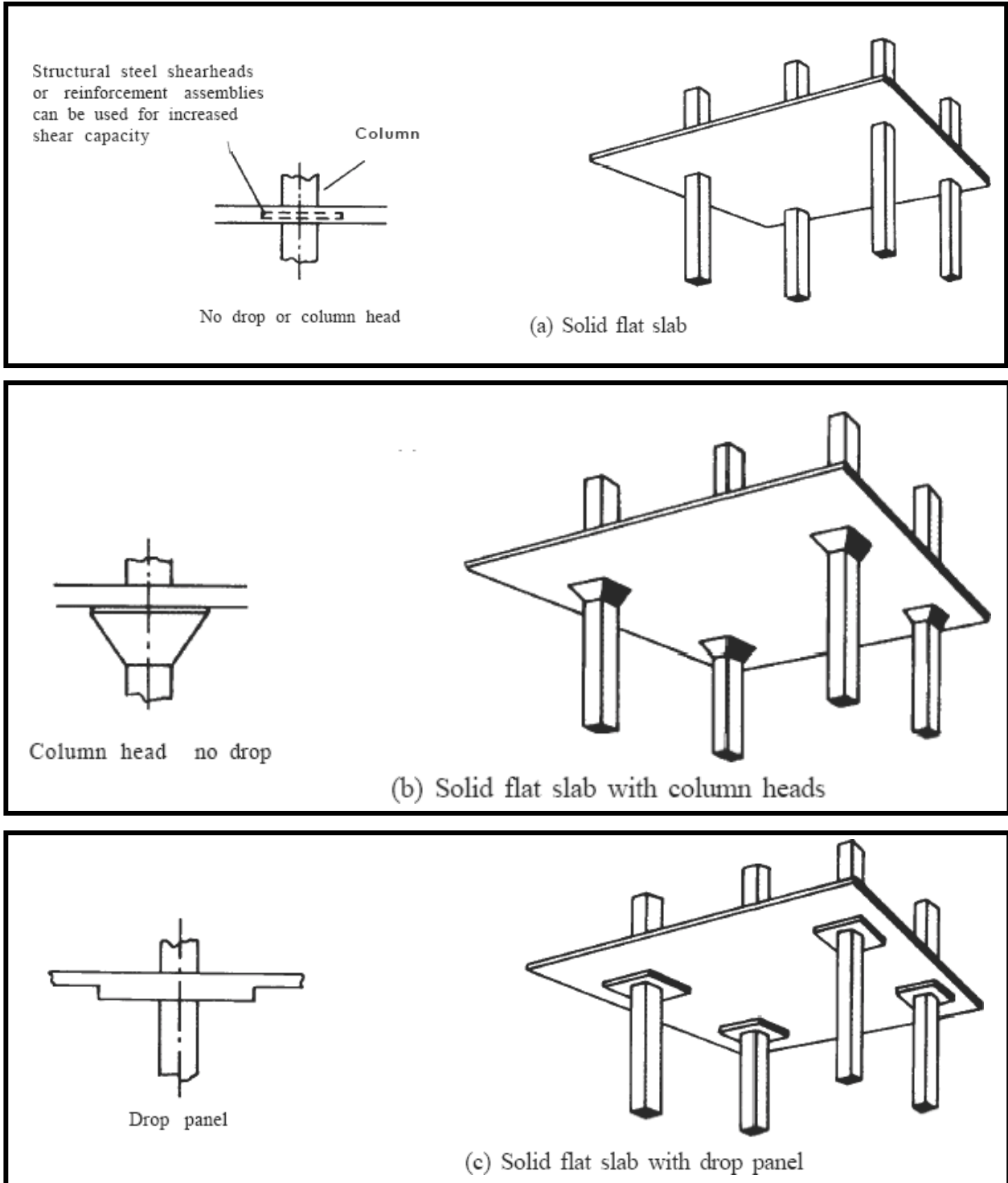

- Beam and slabs – Beams 8m to 20m; slabs 7m to 10m – In modern construction, where there is generally a requirement to minimise depth, the use of wide, shallow band beams is common. The beams, which are either reinforced or post-tensioned, support the one-way spanning slab and transfer loads to the columns

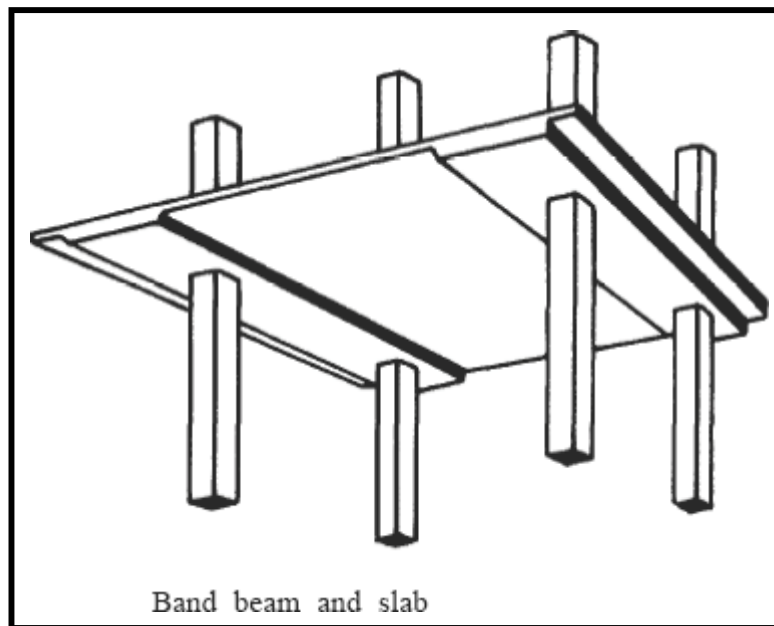

- Ribbed/waffle slabs – Spans 8m to 18m – For longer spans the weight of a solid slab adds to both the frame and foundations costs. By using a ribbed slab, which reduce the self weight, large spans can be economically constructed. The one way spanning ribbed slab provides a very adaptable structures able to accommodate openings. As with beams and slab floors, the ribs can either span between band beams formed within the depth of the slab or between more traditional downstand beams. For long two ways span, waffle slabs give a very material-efficient option capable of supporting high loads.

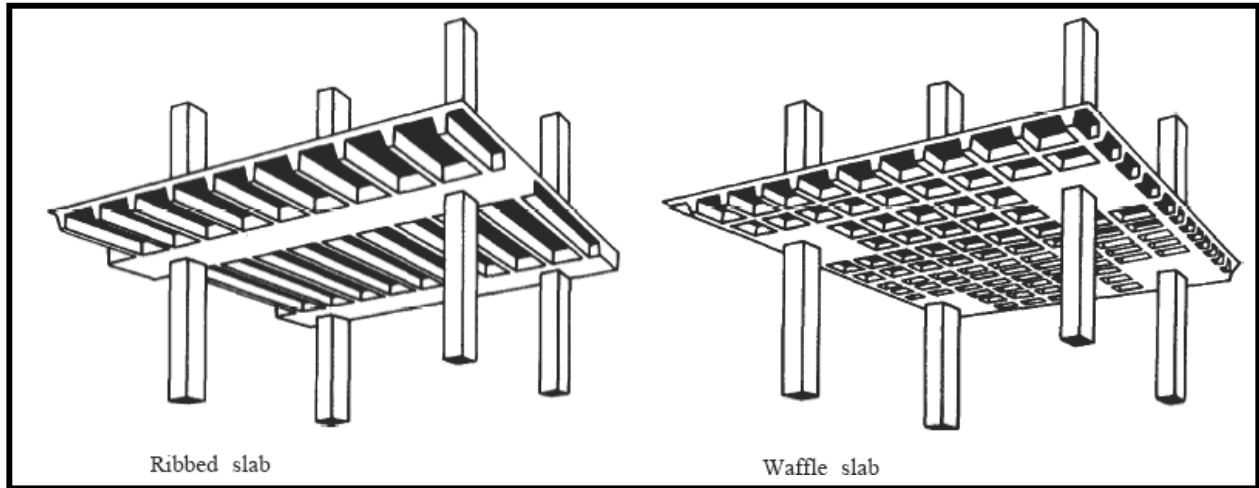

For office construction, flexibility is mostly concerned with likely future changes in the internal space planning. In many cases these do not substantially affect the structure. Core areas, primary services distribution and other major items usually remain fixed, although some additional holes for minor services may be required subsequently. On the other hand, applications such as retail or health care require a higher degree of flexibility for changes in services, and these should be considered at the design stage. A particular design feature of post-tensioned slabs is that the distribution of tendons on plan within the slab does not significantly effect its ultimate strength. There is some effect on strength and shear capacity, but this is generally small. This allows an even prestress in each direction of a flat slab to be achieved with a number of tendons layouts. Here some common layouts of unbonded tendons in flat slab.

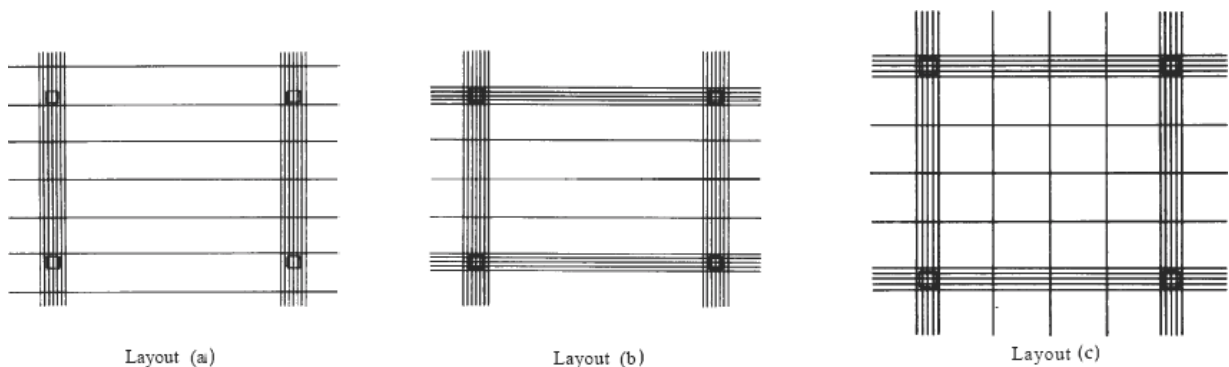

- Layout (a) – It shows the layout of tendons banded over a line of columns in one direction and evenly distributed in the other direction. This layout can be used for solid slabs, ribbed slabs or band beam and slab floors. It offers advantages that holes through the slab can be easily accommodated and readily positioned at the construction stage
- Layout (b) – It shows the tendons banded in one direction, and a combination of banding and even distribution in the other direction. This does not provide quite the same flexibility in positioning of holes, but offers increased shear capacity around column heads. Again, this layout can be used for both solid and ribbed slabs and banded beam construction.
- Layout (c) - It shows banded and distributed tendons in both directions and is logically suitable for waffle flat slabs, but may be employed for other slabs, depending on design requirements.

This offers considerable design flexibility to allow for penetrations and subsequent openings, and the adoption of differing slab profiles, from solid slabs through to ribbed and waffle construction.

Holes through prestressed slabs can be accommodated easily if they are identified at the design stage. Small holes (less than 300x300mm) can generally be positioned anywhere on the slab, between tendons, without any special requirements. Larger holes are accommodated by locally displacing the continuous tendons around the hole.

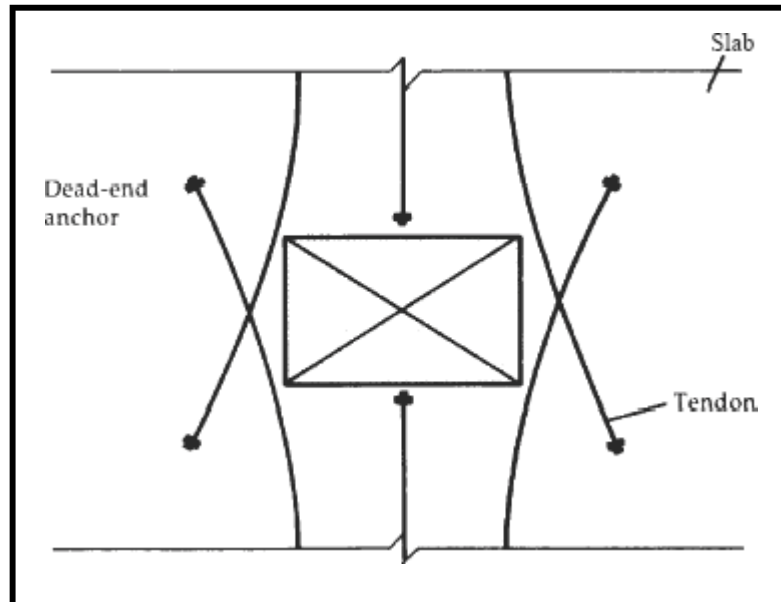

It is good detailing practise to overlap any dead-ended tendons towards the corners of the holes in order to eliminate any cracking at the corners. In ribbed slabs, holes can be readily incorporated between ribs or, for larger holes, by amending ribs spacings or by stopping-off ribs and transferring forces to the adjoining ribs. Holes are more difficult to accommodate once the slab has been cast.

An important aspect regarding PT slabs design is certainly the connection between the floor slab and wall panels, to provide structural integrity. PT slabs on grade must be isolated from the rest of the structure to allow unrestrained shrinkage movement of the slab. Because this shrinkage continues for many months, it is impractical to install direct wall connections during construction. In some cases a perimeter infill strip can be used to isolate the wall/slab connection from the PT slab, but this usually leads to unsightly joints. In these cases the better solution is to modify the building design to provide wall panel support beneath the slab, so that infill slab are not required.

A post-tensioned slab can be highly effective in transferring the steel column loads into the beams and slab thus reducing the possibility of shear failure near the columns.

Post-tensioning design also caters for early shrinkage of the concrete, which commences within hours of pouring. There is a very fine line between providing enough early post-tensioning to mobilize the slab yet avoid bursting of the fresh concrete. Provision of two layers of polythene under the slab minimises sub-grade friction and enhances the efficiency of the applied post-tensioning. The amount of final post-tensioning required in each case depends on many factors including slab size, service loading, concrete strength and subgrade conditions.

PT reinforced concrete can have cracks, though they are controlled. Cracks usually develop when tensioning is performed after significant shrinkage and curling has already occurred. When a residential floor is intended to be the finished surface, such as with chemical staining or diamond polished surfaces, is necessary to take some additional precautions:

- Designs should be based on higher residual compression.
- Stage stressing should be used.
- Concrete slabs should be properly cured.

5. TENSACCIAI slab post-tensioning systems

The TENSACCIAI bonded post-tensioning slab system has been used in many important projects, from residential buildings to bridge and other structures. The system uses up to five strands 12,7 mm or 15,2 mm contained in flat-shaped ducting, and anchored in a single anchorage. Strands are individually stressed and gripped by wedge action. After stressing,

the duct is filled with a cement grout that fully bonds the strands to the surrounding concrete. The TENSACCIAI monostrand system has advantages similar to those of the TENSACCIAI bonded slab post-tensioning system. The TENSACCIAI monostrand system uses 12,7 mm or 15,2 mm diameter strands, which



are given a coating of permanent corrosion-preventing grease and are individually enclosed in an extruded plastic sheathing. The grease and plastic provide double corrosion protection, as well as preventing any bonding between the strands and the surrounding concrete. The plastic sheathing is usually in polyethylene or polypropylene with approximately 1 mm wall thickness.

Each strand is individually anchored, stressed and locked-off. To ensure continuous corrosion protection, special sleeves are used to join the sheathings to the anchorages. The anchorages are provided with a protective cap.

PTS multi-strand system

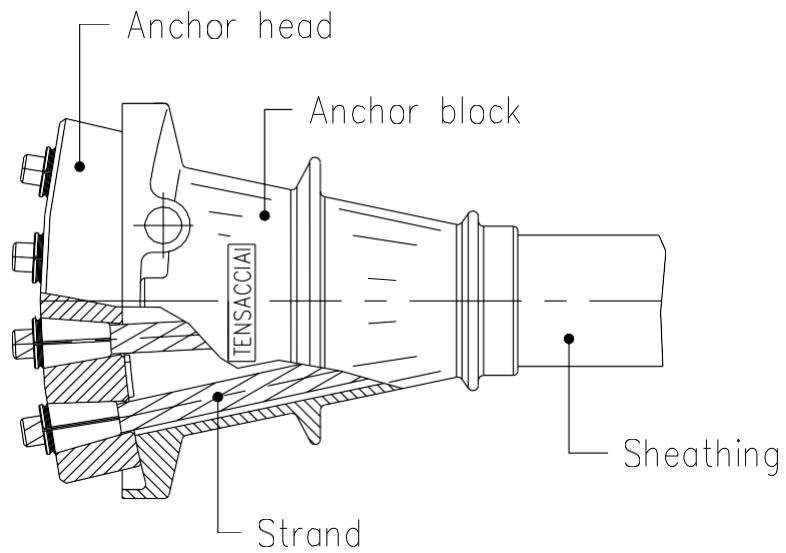

Anchorage

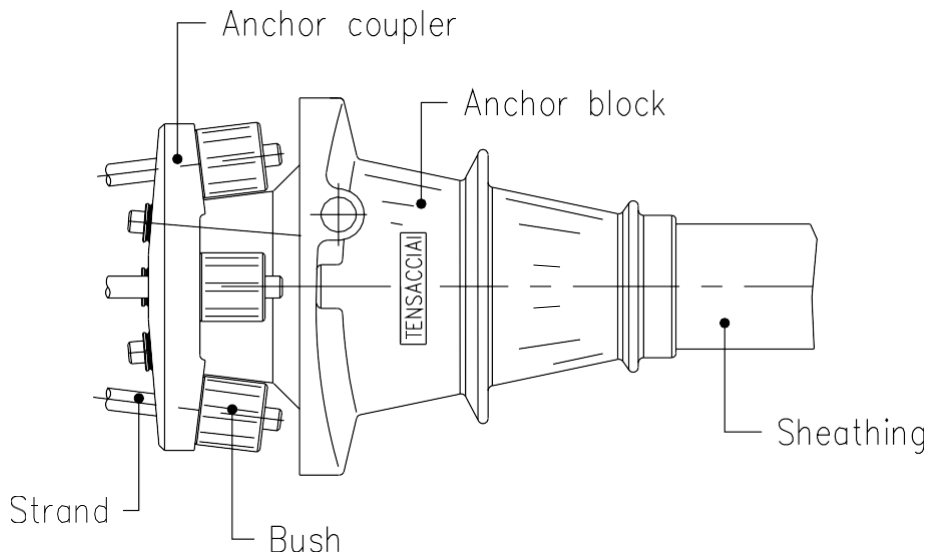

Coupler

PTS multi-strand system

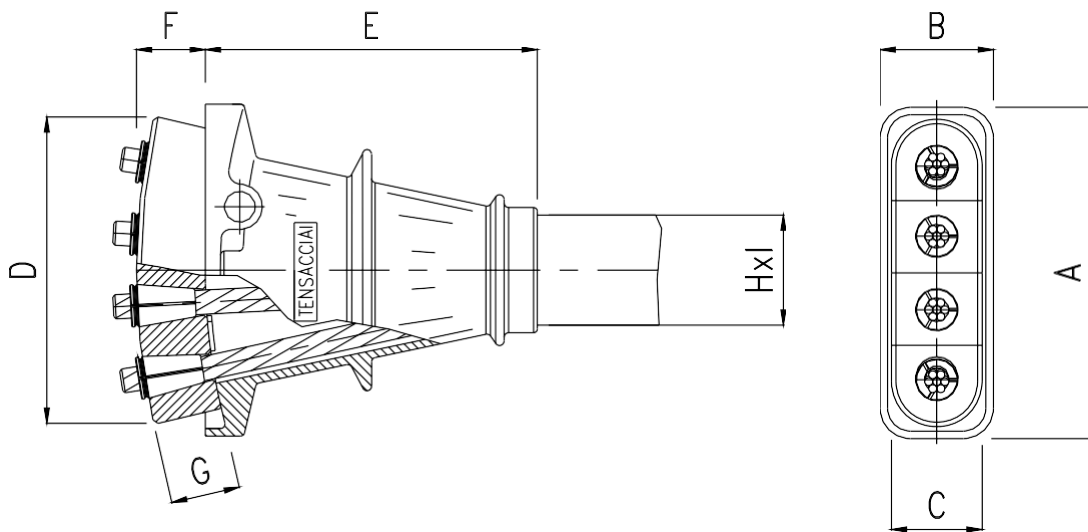

	A	B	C	D	E	F	G	H	I
PTS type	all dimensions in mm								
3 PTS 13 (3 strands Ø 12,7 mm)	170	75	50	125	190	45	45	72	20
3 PTS 15 (3 strands Ø 15,2 mm)	170	75	60	155	190	45	45	72	20
4 PTS 13 (4 strands Ø 12,7 mm)	220	75	50	160	220	45	45	72	20
4 PTS 15 (4 strands Ø 15,2 mm)	220	75	60	205	220	45	45	72	20
5 PTS 13 (5 strands Ø 12,7 mm)	220	75	50	200	220	45	45	72	20
5 PTS 15 (5 strands Ø 15,2 mm)	265	75	60	250	270	45	45	92	22

PTS multi-strand system

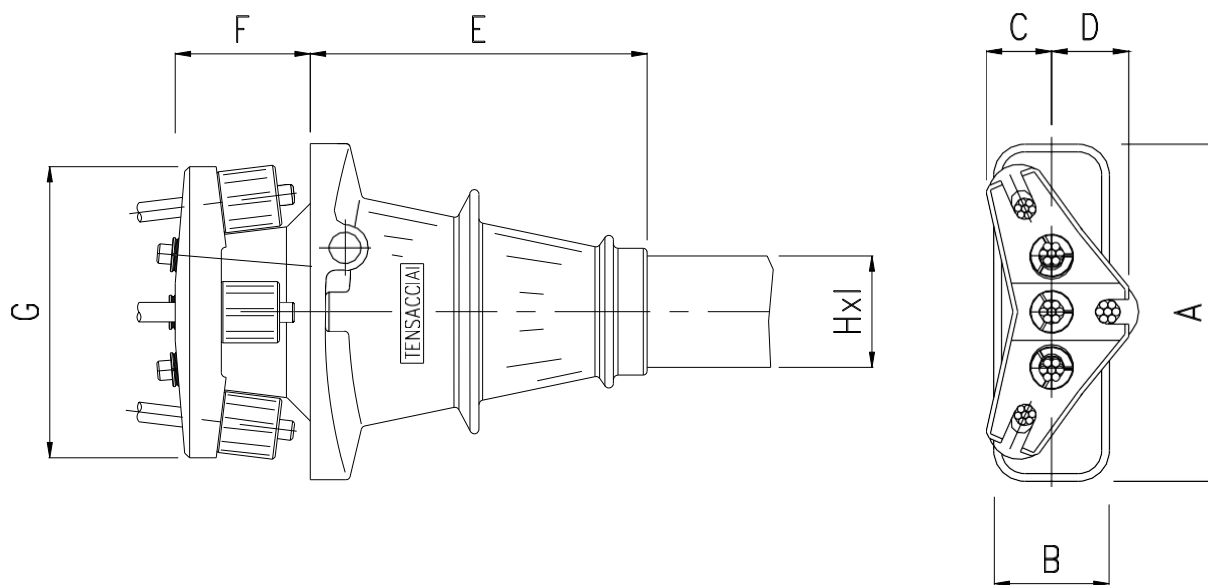

	A	B	C	D	E	F	G	H	I
PTS type	all dimensions in mm								
3 PTS 13 (3 strands Ø 12,7 mm)	170	75	44	50	190	88	190	72	20
3 PTS 15 (3 strands Ø 15,2 mm)	170	75	44	62	190	104	220	72	20
4 PTS 13 (4 strands Ø 12,7 mm)	220	75	50	50	220	88	160	72	20
4 PTS 15 (4 strands Ø 15,2 mm)	220	75	53	53	220	103	250	72	20
5 PTS 13 (5 strands Ø 12,7 mm)	220	75	50	50	220	88	242	72	20
5 PTS 15 (5 strands Ø 15,2 mm)	265	75	53	53	270	104	295	92	22

Mono-strand System

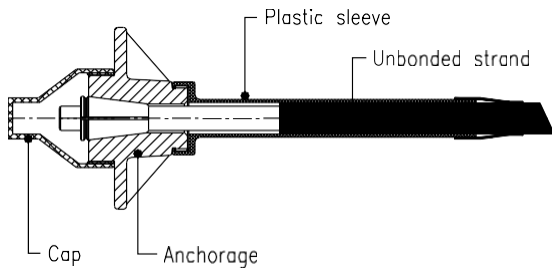

Live end

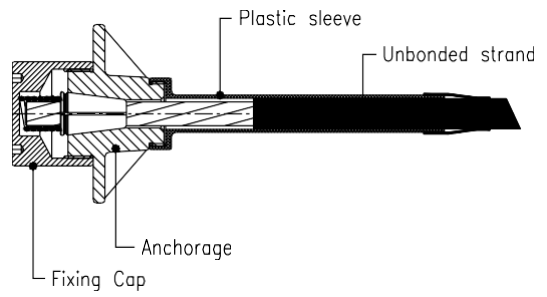

Dead end

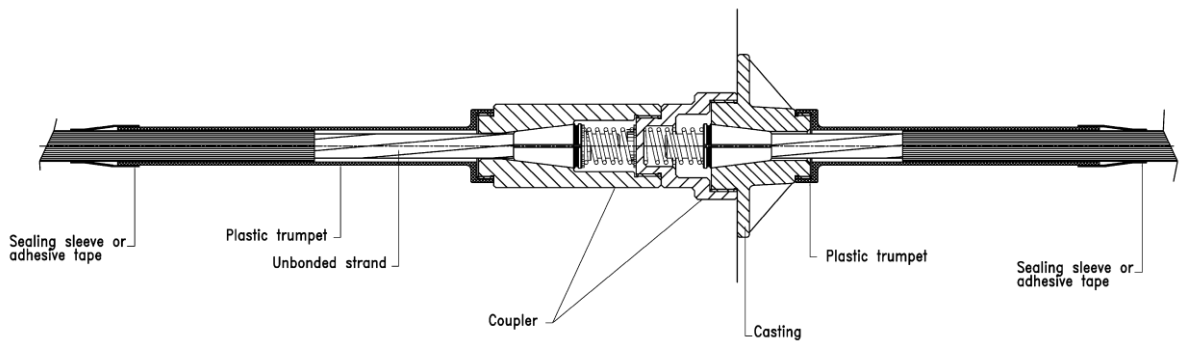

Coupler

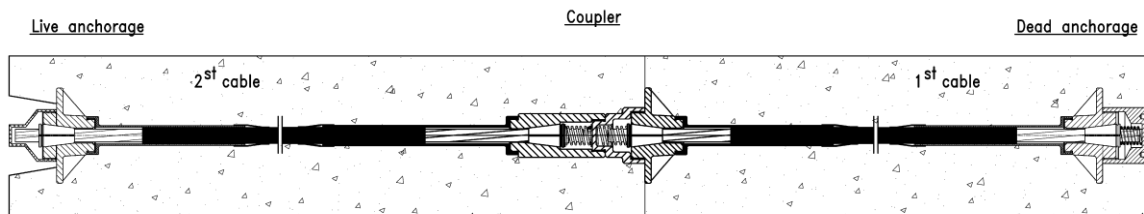

Typical application

Mono-strand System

Front View

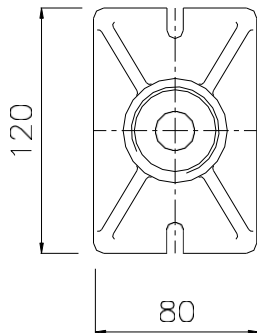

Longitudinal View

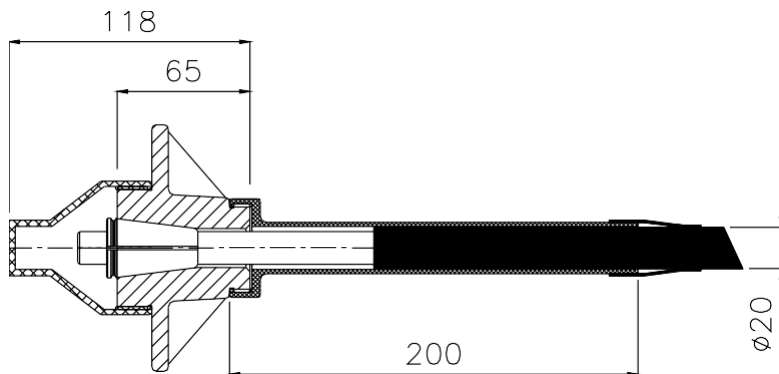

Live end

Front View

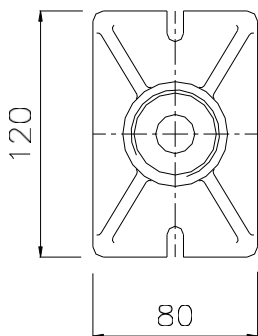

Longitudinal View

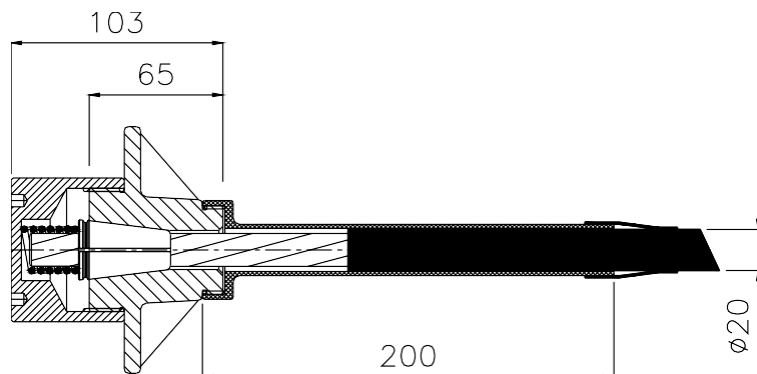

Dead end

Mono-strand System

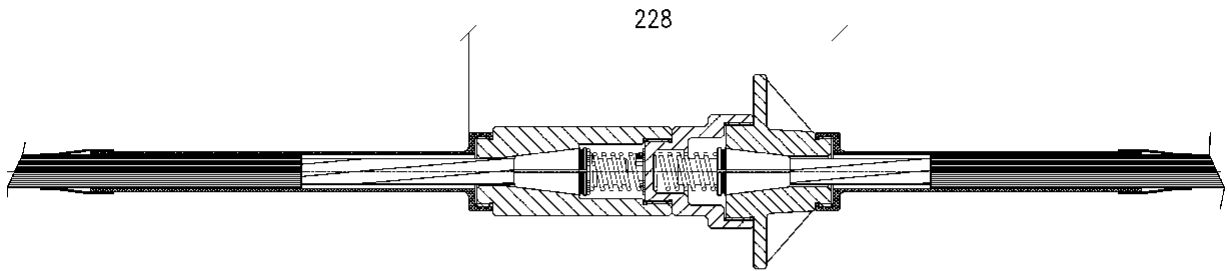

Coupler

Mono-strand System

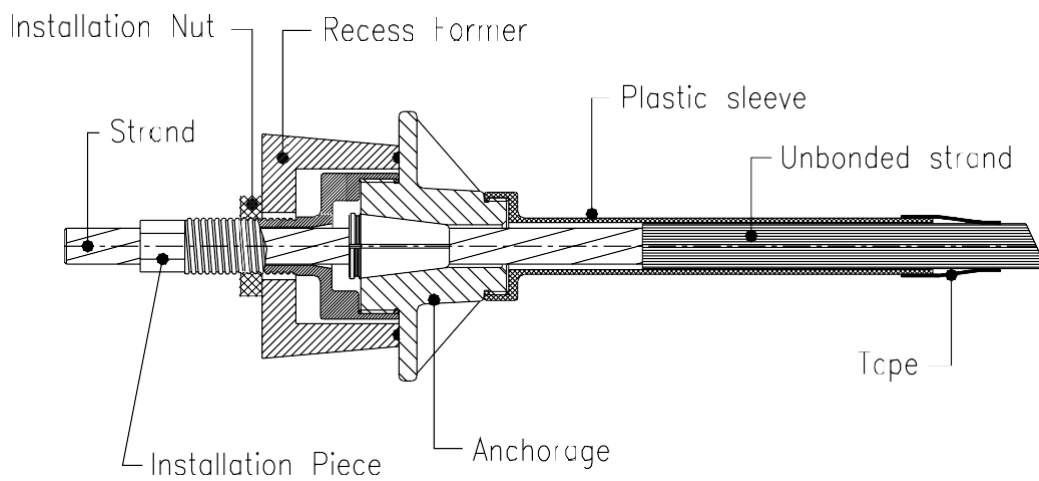

Recess former system for mono-strand anchorage

Mono-strand System

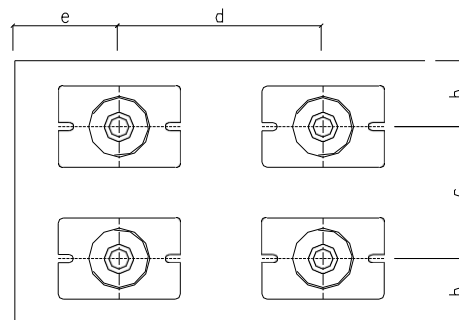
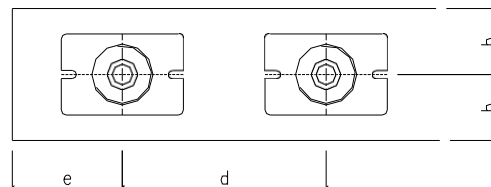

Concrete strength at the time of stressing	b	c	d	e
	all dimensions in mm			
$f_{cm,0 - cyl} = 25 \text{ MPa}$	75	140	220	110
$f_{cm,0 - cyl} = 33 \text{ MPa}$	65	120	200	100
$f_{cm,0 - cyl} = 45 \text{ MPa}$	55	100	160	80

6. Post tensioning slabs - Construction

The sequence of construction of post-tensioned slabs is straightforward and typically includes the points given below. A number of aspect such as prefabrication of tendons, the reduction in quantity of steel to be fixed and large pour sizes help to speed the construction.

6.1 *Suspended slabs*

The following items specifically impact the construction of suspended slabs and should be included in the contract documents prepared by the designer:

- Frame geometry (member size and spacing)
- Reinforcement (type, size, location, and method of support)
- Shear connectors, if required
- Construction joint location
- Metal deck (type, depth, and gage), if required
- Shoring, if required
- Tolerances (forms, structural steel, reinforcement, and concrete)

The levelness of suspended slabs depends on the accuracy of formwork and strike off but is further influenced (especially in the case of slabs on metal decking) by the behaviour of the structural frame during and after completion of construction. Each type of structural frame behaves somewhat differently; it is important for the contractor to recognize these differences and plan accordingly.

6.1.1 Slabs with removable forms

Cast-in-place concrete construction can be either post-tensioned or conventionally reinforced. Both of these systems are supported during initial concrete placement, and they will deflect when supporting shores are removed. Post-tensioned systems are normally used when larger spans are necessary or when the structural system is relatively shallow for the spans considered. Post-tensioned systems use high-strength

steel tendons that are tensioned using a hydraulic jack designed for that purpose. The magnitude of floor slab deflection after supports are removed is less than that of comparable floors reinforced with conventional deformed reinforcing steel. At times, dead load deflection is entirely eliminated by the use of post-tensioning.

6.1.2 Slabs on carton forms

Slabs on carton forms are a special application of slabs with removable forms. These slabs are necessary when slabs at ground level should remain independent of soil movement. Slabs on carton forms are most commonly used when soils at the building site are expansive clays subject to significant movement as a result of moisture variation. They provide a more economical construction solution than conventional framing systems, which require a crawl space to remove forms. The cardboard carton forms deteriorate in the months following construction, eventually leaving the desired void space below the slab and forcing the slab to span between supporting foundation elements.

6.1.3 Slabs on metal deck

Construction of slabs on metal deck involves the use of a concrete slab and a supporting platform consisting of structural steel and metal deck. The structural steel can be shored or unshored at the time of concrete placement, and the metal deck serves as a stay-in place form for the concrete slab. This construction can be composite or noncomposite. The supporting steel platform for slabs on metal deck is seldom level. Variation in elevations at which steel beams connect to columns and the presence of camber in some floor members combine to create variations in the initial elevation of steel members.

6.1.4 Composite slabs on metal deck

In composite construction, the composite section (concrete slab and steel beams) will work together to support any loads placed on the floor surface after the concrete has hardened. Composite behavior is normally developed through the use of shear

connectors welded to the structural steel beam. These shear connectors physically connect the concrete slab to the beam and engage the concrete slab within a few feet of the steel beam. Unshored composite construction is the more common method used by designers because it is less expensive than shored construction. In unshored construction, the structural steel beams are sometimes cambered slightly during the fabrication process. This camber is intended to offset the anticipated deflection of that member under the weight of concrete. Ideally, after concrete has been placed and the system has deflected, the resulting floor surface will be level.

6.1.5 Topping slabs on precast concrete

A cast-in-place concrete topping on precast-prestressed concrete units involves the use of precast elements as a combination form and load-carrying element for the floor system. The cast-in-place portion of the system consists of a topping of some specified thickness placed on top of the precast units. The topping can be composite or noncomposite. In either case, added deflection of precast units under the weight of the topping slab is normally minor, so the finished surface will tend to follow the surface topography established by the supporting precast units.

6.2 Slabs on ground

The following items should be specified in the contract documents prepared by the designer:

- Base and sub base materials, preparation requirements, and vapour retarder, if required
- Concrete thickness
- Concrete compressive strength, flexural strength, or both
- Concrete mixture proportion requirements
- Joint locations and details
- Reinforcement (type, size, and location), if required
- Surface treatment, if required
- Surface finish
- Tolerances (base, sub base, slab thickness, and surface)
- Concrete curing
- Joint filling material and installation
- Special embedment
- Preconstruction meeting, quality assurance, and quality control

The performance of a slab-on ground depends on the integrity of both the soil-support system and the slab; therefore, specific attention should be given to the site preparation requirements, including proof rolling. In most cases, proof rolling results are far more indicative of the ability of the soil-support system to withstand loading than the results from in-place tests of moisture content or density are. A thin layer of graded, granular, compactable material is normally used as fine grading material to better control the thickness of the concrete and to minimize friction between the base material and the slab. Proper moisture protection is essential for any slab-on-ground where the floor will be covered by moisture-sensitive flooring materials such as vinyl, linoleum, wood, carpet, rubber, rubber-backed carpet tile, impermeable floor coatings, adhesives, or where moisture sensitive equipment, products, or environments exist, such as humidity-

controlled or refrigerated rooms. A vapour retarder is a material that is intended to minimize the transmission of moisture upward through the slab from sources below.

The selection of a vapour retarder or barrier material should be made on the basis of protective requirements and the moisture-related sensitivity of the materials to be applied to the floor surface. The increased thickness offers increased resistance to moisture transmission while providing greater durability during and after installation. Placing concrete in direct contact with the vapour retarder or barrier, however, requires additional consideration if potential slab-related problems are to be avoided. When compared with identical concrete cast on a draining base, concrete placed in direct contact with a vapour retarder or barrier has been shown to exhibit significantly larger length change in the first hour after casting, during drying shrinkage, and when subject to environmental change.

Reinforcement in non-structural slab-on-ground installations is provided primarily to control the width of cracks that occur. This reinforcement is normally furnished in the form of deformed steel bars, welded wire reinforcing, steel fibres, or post tensioning tendons. Combinations of various forms of reinforcement have proved successful. Deformed reinforcing steel or post-tensioning tendons should be supported and tied together sufficiently to minimize movement during concrete placing and finishing operations. Chairs with sand plates or precast-concrete bar supports are generally considered to be the most effective method of providing the required support. The use of high-strength steel tendons as reinforcement instead of conventional mild steel temperature and shrinkage reinforcement allows the contractor to introduce a relatively high compressive stress in the concrete by means of post tensioning. This compressive stress provides a balance for the crack-producing tensile stresses that develop as the concrete shrinks during the curing process. Stage stressing, or partial tensioning, of the slab on the day following placement can result in a significant reduction of shrinkage cracks. Construction loads on the concrete should be minimized until the slabs are fully stressed (PTI 1990; PTI 1996). For guidelines on installation details, contact a concrete floor specialty contractor who is thoroughly experienced with this type of installation.

6.3 Work method statement

WORK METHOD STATEMENT SLAB POST TENSIONING – INSTALL / STRESS / SEAL & GROUT	
STEP	DETAILS
1	Confirm site drawings are the latest revision and are approved for construction.
2	Complete formwork/false work and stop-ends for relevant concrete pour (by others). Check that access and required work areas are clear and safe for installation requirements.
3	Check and confirm that stressing material deliveries are as per delivery docket issued and retain docket in site file.
4	Set out location of stressing anchorages and pockets in accordance with the issued 'for construction' drawings. If drawing is issued 'for approval' only, confirm with supervisor if OK to use.
5	Slot and drill forms (if required).
6	Install anchorages onto edge board as per approved drawings. Ensure that all necessary personal protective equipment is worn at all times – i.e. gloves, safety glasses, protective footwear, and safety helmets.
7	Mark out tendon spacing and lay duct as per approved drawings
8	Lay pre-stressing duct, install any anti-burst reinforcement and tape duct to anchorages
9	Carefully place strand coil in strand frame prior to cutting retaining straps with tin snips. If strand frame needs to be lifted into position (by crane), use lifting frame. If frame has no lifting lugs, ensure slings pass through coil, and not off frame only
10	Position strand frame (coil) adjacent to work area and away from thoroughfares. Use safety goggles whenever strand is being cut. Ensure area is of sufficient strength to support weight of coil. DO NOT use heat-type cutting devices to cut strand

11	Push stand for all tendons as per drawing details. Ensure pushing area is barricaded and signage is placed to maintain safe work areas. Stand clear of strand being drawn from coil into duct. DO NOT stand between pusher and coil
12	After correct amount of stand has been placed into duct for each tendon, create dead-end (onion) on each strand
13	Straighten and profile duct as per drawing details. Check straights and profile before fixing to deck using staples. Place grout tube into anchor head grout port, and into end of duct at dead end
14	Ensure that anchorages are positioned according to the design and fixed so they do not move during normal construction activities. Ensure that anti-burst reinforcement is present and fixed central to anchorage zone
15	Check installation has been completed to the best of your ability, and advise design engineer or builder/contractor that installation is complete, and ready for engineer's inspection. Sign off relevant areas.
16	During concrete pour, check that ducts and strands are not damaged by concreter. If damage occurs, notify concreter and arrange to fix.
17	At completion of concrete pour, check that all anchors are clear of slurry etc. Check that test cylinders have been taken during pour and stored on site in conditions similar to slab being poured. Notify supervisor if cylinders are not taken.
18	After edge board/ pan has been stripped, grease holes in anchor block/coupling block, place anchorage components over protruding strands and hard up against casting. Place two-piece wedges such that join is vertical in seat. Seat firmly with hammer. Ensure anchor is hard up to anchorage casting and clear of all slurry. Paint strand to show datum for stressing extensions.
19	Check stressing jack and gauge are accompanied by valid and up-to-date calibration (kept in gauge box). Check nose on jack (or curved nose) to ensure recess is maintained. Ensure jack operator is experienced in the use of the equipment.
20	Inform site superintendent that stressing is to commence in the area. Ensure that a clear area is maintained to a minimum of 2 m radius around anchorages (live and dead ends) being stressed. Place twin plywood barricade directly behind line of jacks, and place and maintain all "Stressing in Progress" signs in appropriate locations around the stressing area. If formwork has been removed below, barricade the areas below the slab to the same requirements as above.

21	Check the required load on the calibration chart, and confirm the gauge pressure required.
22	Stress tendons in order from furthest to closest reachable position to ensure no person is standing in direct line of the jack, or previously stressed strands. Place stressing jack into position over chosen strand. Connect hydraulic pump to jack, and pressure gauge to pump.
23	Stress tendons to the required load and in accordance with the calibration report and check seating of wedges at live anchorages after lock-off. Ensure that stressing load is applied gradually and evenly.
24	Measure tendon extensions, complete standard stressing form and forward to the principal contractor for review and approval. (Note: Designated slabs reports to be forwarded to design engineer for approval).
25	At completion of each tendon stressing, ensure barricading and signage is maintained for a period of at least two hours after full stress has been completed. Notify builder/client that no drilling/coring is to be performed on the area until grouting is completed or unless otherwise approved. Notify supervisor that stressing is completed and that signage is in place.
26	Obtain verbal approval of stressing results from principal contractor or design engineer prior to cutting off excess strand and barging up anchorages recesses.
27	Cut all tendons, ensuring that specified concrete cover can be achieved, using friction cutter, and place off-cuts in bins provided by others. DO NOT use heat-type cutting devices. Wear safety goggles during all cutting operations.
28	Dry pack any edge recesses with sand/cement mix and fill 'top of slab' recesses with concrete. Use rubber gloves to prevent cement burns to skin.
29	Grout tendons. Before commencing grouting, all vents/drains should be opened and blown through to check for clear. Grout mix to be 8 litres of water per 20 kg bag of cement. Any required additives (i.e. shrinkage agents etc) to be added only on design engineer's request. Grout cube to be taken only on engineer's request. If formwork has been removed below barricade areas directly below slab. Dust masks, safety goggles and gloves should be worn at all times when grouting.

30	Commence grouting tendon from one end through standard hose connected to dead end grout tube. Bleed minimum of 1 litre into bucket at other end, and then close vents when grout issues of same consistency as that at point of injection. Grout injection should be continuous, to avoid blockages or the formation of voids in the grout column.
31	Once outward vent is closed, pressurize duct to minimum of about 100 kPa, maximum of 250 kPa and hold for a period of 1 minute using pressure relief valve on pump.
32	Remove grout tubes not less than 24 hours after tendon grouting is completed. Top up any vents as necessary.
33	Clean up works areas and make safe any obstruction caused by stressing works.
34	Forward all records and documentation to supervisor / project engineer for filing in project file.

7. Post tensioning slabs - Durability

Many things affect the ability to achieve long-term durability. Concrete quality, finishing procedures, weather conditions/placing environment, joints, and sub grade just to mention a few. Quality concrete is certainly one of the most important parts of the equation for durable floors. The best contractor in the world will not be able to meet expectations without it. Conversely, a good concrete mix design will not overcome improper procedures at the batch plant or in the field.

The components in all concrete mix designs are basically the same. However, durable post-tensioned slabs demand special requirements. Priority should be focused on developing a low-shrinkage mix that minimizes cracking and curling while maintaining design strength. The concrete also should be reasonably easy to place, finish, and pump.

Concrete cover, used as protection for reinforcement against weather and other effects, is measured from the concrete surface to the outermost surface of the steel, or prestressing duct. Where stirrups enclose the longitudinal reinforcement or prestressing ducts, such as in beams, the minimum cover specified is to the outer surface of the stirrup. The minimum specified cover depends on whether the concrete surface is “exposed to weather” or not. This means direct contact to both moisture and temperature changes. Slab and beams soffit are not considered as exposed, unless subjected to wetting, including condensation. Also, if alternative methods of corrosion are provided, the minimum cover requirements may be waived. For durability the degree of the needed corrosion protection depends upon:

- Exposure of member (interior or exterior member)
- Quality of concrete
- Cover to reinforcement
- Design parameters, such as the level of precompressing
- Detailing (crack mitigation rebar)
- Geographical ambient environment

A particular attention to the problem of durability is important when post-tensioned slabs are used in parking construction, especially when they are located in cold climate areas. In these situations, durability design systems control entry of de-icing salts and protect reinforcing steel even when chloride ions penetrate the concrete. To achieve these goals, redundant durability systems are needed, that is, if one system fails, a backup system must come into play. The recommended approach incorporates several durability elements: --The first and most basic durability system is the concrete used in the slab. Low permeability requires a low water-cement ratio. --The desired drainage slope for floors is 2 percent, but never less than 1.5 percent. --Surface sealers slow water and chloride entry into the concrete. They are not water roofers, however, and don't bridge cracks. --Control joints and construction joints must be sealed with a high-quality traffic-grade polyurethane sealer to prevent de-icing salt entry and subsequent deterioration of rebar. --Increasing concrete cover over the reinforcing steel increases the distance the chlorides must travel in the concrete to cause corrosion. --Epoxy coated rebar increases the durability of bridge decks by withstanding the deteriorating effects of de-icing salts. --Covering the post-tensioning tendon from anchorage to anchorage prevents contact with the concrete or with migrating water and de-icing salts.

8. Future prospects

The recent intense construction experience has provided fertile ground for the development of innovative and practical solutions to enhance the acceptability of these slabs in the industry. A key factor in the successful use of PT slab in the future is early involvement with buildings designers to ensure that structural details are compatible with the PT slab system. PT slabs present an excellent vehicle for designers and contractors to provide their client with maintenance free, high performance floors which live up to expectations.

TENSACCIAI has many years of experience in the installation of post-tensioning systems and can bring measurable benefits to your project.